

URBANGAMES23_BLOQUE 2.4 TEJIDOS / MANUALES

Tipologías Baja Densidad
Vivienda unifamiliar

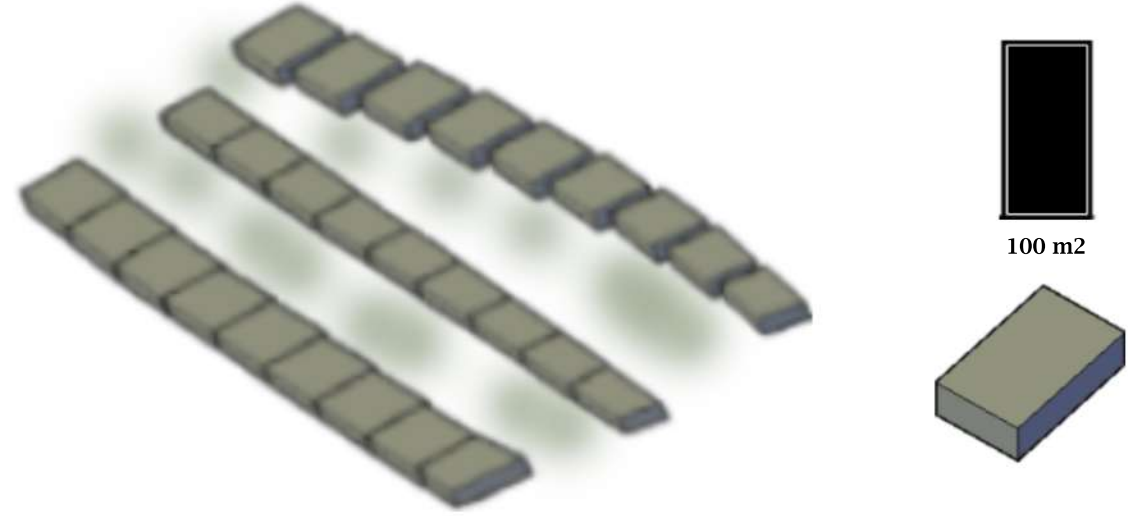

Tipologías Media Densidad
Vivienda unifamiliar

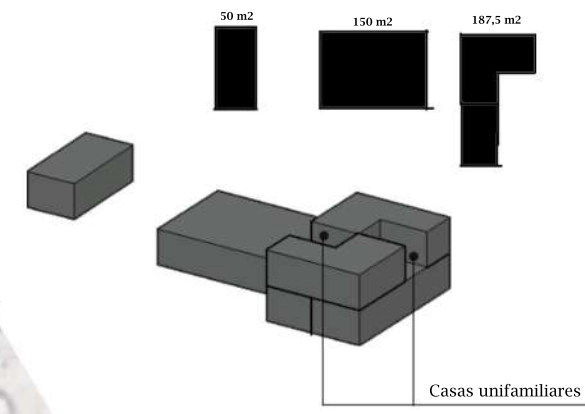
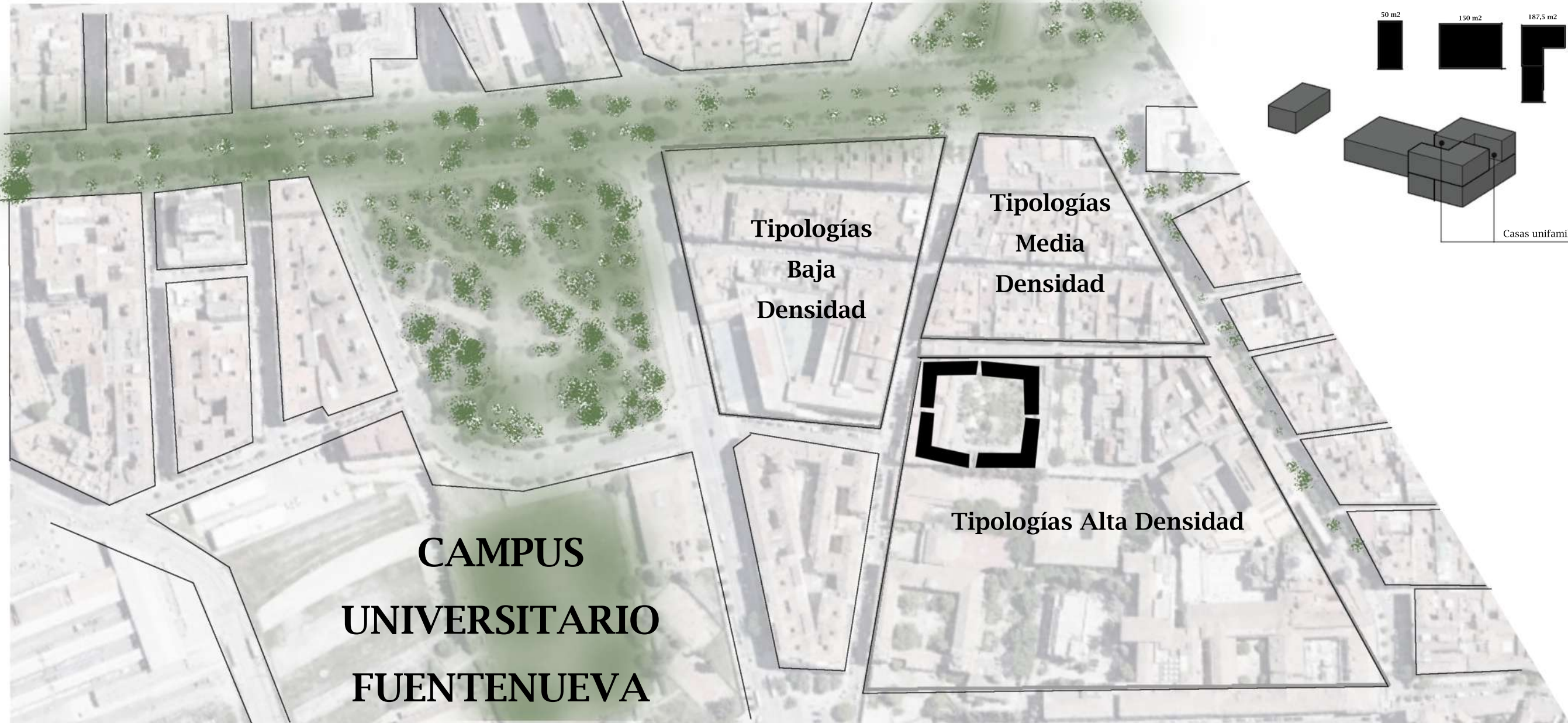
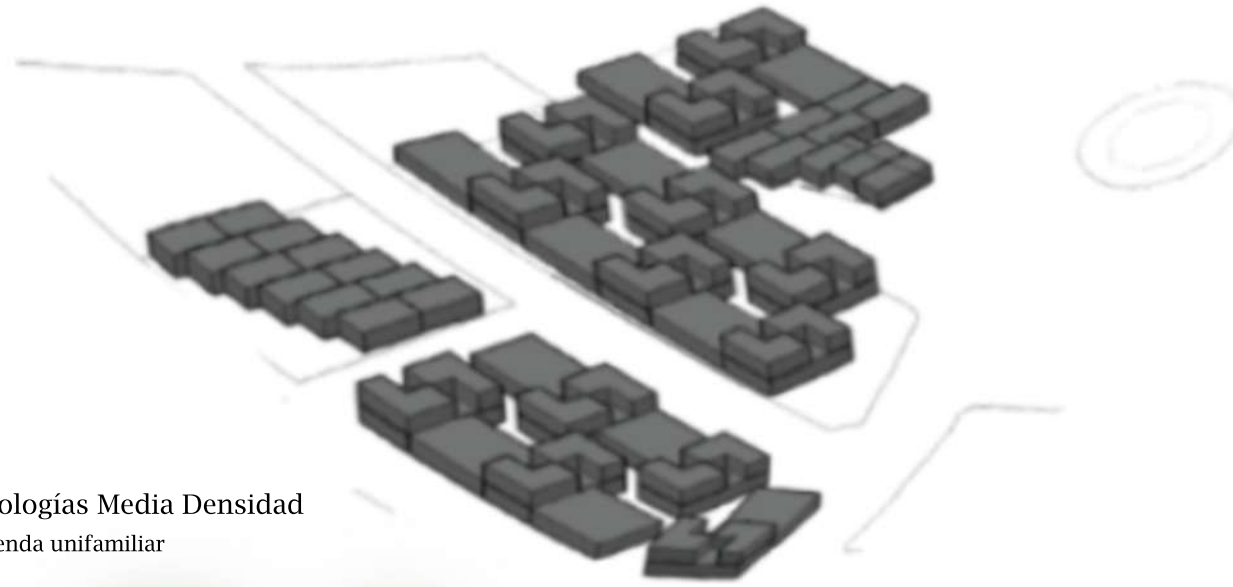

Tipologías Alta Densidad

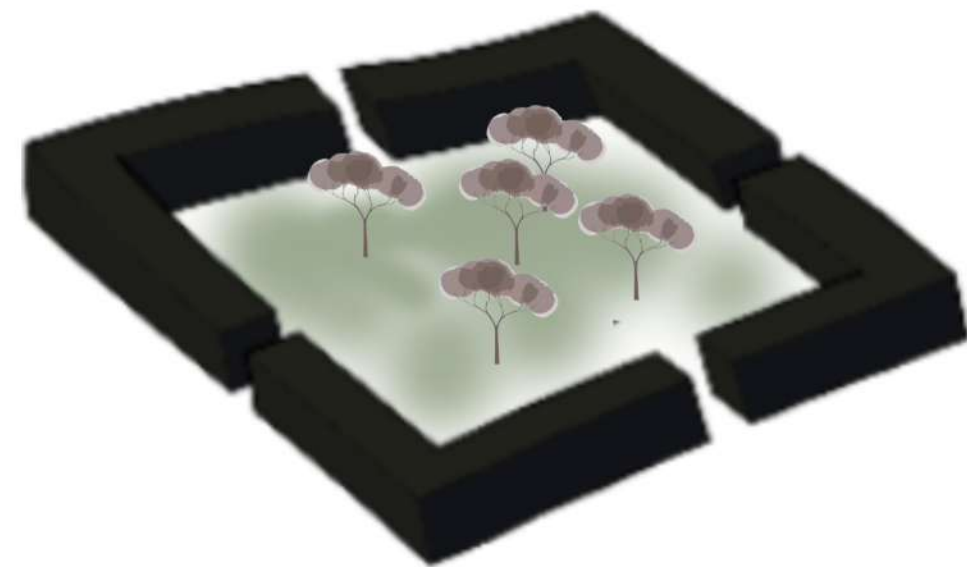
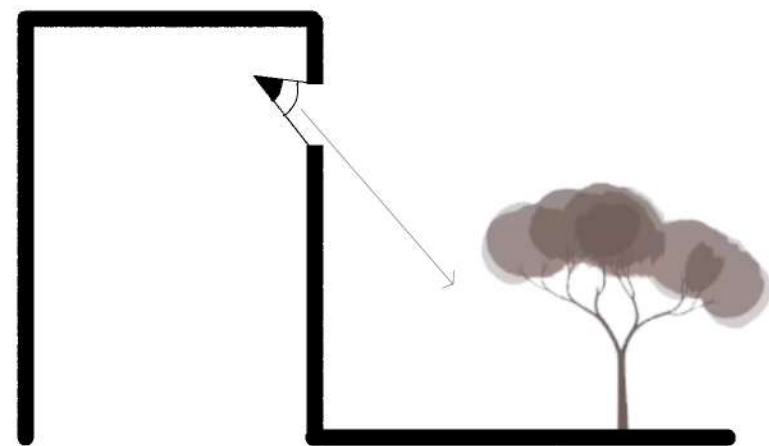

7500 m2



Bloque de viviendas

SAN MARCO _ VENECIA

Ax: 110.000m2
Ex: 102.750 m2
FSI = 0,93
Bx: 14.500 m2
GSI = 0,13
OSR = 0,94
L= 6

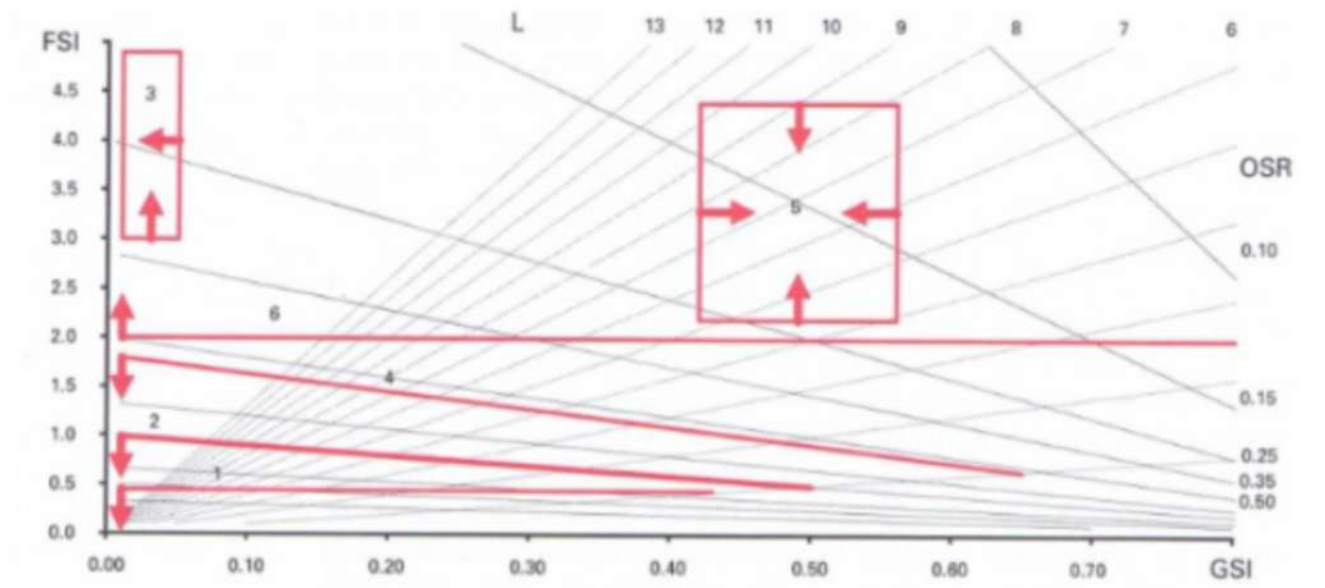

CENTRO GRANADA

Ax: 456.000m2
Ex: 376.000 m2
FSI = 0,82
Bx: 160.000 m2
GSI = 0,35
OSR = 0,80
L = 3

